

VAL-CP-3S-350

Order No.: 2859521



Pluggable type 2 arrester (surge arrester) for 3-phase current supply networks with separate N and PE (5-conductor system: L1, L2, L3, N, PE), with remote indication contact. Overall width: 48 mm.



Commercial data	
EAN	4017918977610
Pack	1 pcs.
Customs tariff	85363030
Weight/Piece	0.4155 KG
Catalog page information	Page 26 (TT-2007)

Product notes

WEEE/RoHS-compliant since:
06/27/2006

**Technical data****Standards**

Housing material	PBT
Inflammability class acc. to UL 94	V0
Color	gray

Standards for air and creepage distances	DIN VDE 0110-1
	IEC 60664-1: 1992-10
	IEC 61643-1
Surge voltage category	III
Pollution degree	2
Degree of protection	IP20
Mounting type	DIN rail 35 mm
Design	DIN rail module, two-section, divisible
Number of positions	4
Ambient temperature (operation)	-40 °C ... 80 °C
Message surge protection faulty	Optical, remote indicator contact
Direction of action	3L-N & N-PE
Width	49.20 mm
Height	70.00 mm
Length	98.50 mm
Protective circuit	
IEC category	II
EN type	T2
Nominal voltage U_N	240 V AC (230/400 V AC ... 240/415 V AC)
	415 V AC (L-L)
Arrester rated voltage U_C (L-N)	350 V AC
Arrester rated voltage U_C (N-PE)	264 V AC
Nominal frequency f_N	50 Hz
	60 Hz
Rated load current	40 A (40 A ... 63 A)
	63 A (10 mm ²)
Discharge current to PE at U_C	$\leq 1 \mu\text{A}$
Power consumption without load P_c	$\leq 3.5 \text{ mW}$
Max. discharge surge current I_{max} (8/20) μs maximum (L-N)	120 kA (all channels)
Max. discharge surge current I_{max} (8/20) μs maximum (N-PE)	40 kA
Nominal discharge surge current I_n (8/20) μs (L-N)	60 kA (all channels)
Nominal discharge surge current I_n (8/20) μs (N-PE)	20 kA
Impulse operate voltage at 6 kV (1.2/50) μs (N-PE)	$\leq 1.5 \text{ kV}$

Protection level U_p (L-N)	≤ 1.4 kV
Protection level U_p (N-PE)	≤ 1.5 kV
Residual voltage (L-N)	≤ 1.4 kV (at I_n)
	≤ 1.2 kV (at 10 kA)
	≤ 1.1 kV (at 5 kA)
	≤ 1 kV (at 3 kA)
Residual voltage (L-PE)	≤ 1.6 kV (at I_n)
	≤ 1.3 kV (at 10 kA)
	≤ 1.2 kV (at 5 kA)
	≤ 1.1 kV (at 3 kA)
Residual voltage (N-PE)	≤ 0.5 kV (at I_n)
	≤ 0.3 kV (at 10 kA)
	≤ 0.25 kV (at 5 kA)
	≤ 0.2 kV (at 3 kA)
Clamping voltage SVR (L-N)	≤ 0.9 kV
Clamping voltage SVR (L-PE)	≤ 1.2 kV
Clamping voltage SVR (N-PE)	≤ 1.2 kV
Clamping voltage ringwave (L-N)	≤ 1.2 kV (category C3 20 kV/10 kA)
	≤ 1.1 kV (category C2 10 kV/5 kA)
	≤ 1 kV (category B3/C1 6 kV/3 kA)
Clamping voltage ringwave (L-PE)	≤ 1.3 kV (category C3 20 kV/10 kA)
	≤ 1.2 kV (category C2 10 kV/5 kA)
	≤ 1.1 kV (category B3/C1 6 kV/3 kA)
Clamping voltage ringwave (N-PE)	≤ 1.5 kV (category C3 20 kV/10 kA)
	≤ 1.4 kV (category C2 10 kV/5 kA)
	≤ 1.2 kV (category B3/C1 6 kV/3 kA)
Response time (L-N)	≤ 25 ns
Response time (L-PE)	≤ 100 ns
Response time (N-PE)	≤ 100 ns
Max. required backup fuse with branch wiring	125 A (gL/gG)
Max. required backup fuse with V-type through wiring	40 A
Short circuit resistance I_{cc} with max. backup fuse (effective)	25 kA
Short circuit current self-quenching	100 A (N-PE)

Connection, protective circuit

Type of connection	Screw connection
Connection type IN	Biconnect screw terminal block
Connection type OUT	Biconnect screw terminal block
Connection system	Biconnect terminal block
Screw thread	M5
Tightening torque, min	4.5 Nm
Stripping length	16 mm
Conductor cross section stranded min.	2.5 mm ²
Conductor cross section stranded max.	16 mm ²
Conductor cross section solid min.	2.5 mm ²
Conductor cross section solid max.	25 mm ²
Conductor cross section AWG/kcmil min.	12
Conductor cross section AWG/kcmil max	4

Remote indicator contact

Connection name	Remote fault indicator contact
Schaltfunktion_Int	PDT contact
Type of connection	Pluggable screw connection
Screw thread	M2
Tightening torque, min	0.25 Nm
Stripping length	7 mm
Conductor cross section stranded min.	0.14 mm ²
Conductor cross section stranded max.	1.5 mm ²
Conductor cross section solid min.	0.14 mm ²
Conductor cross section solid max.	1.5 mm ²
Conductor cross section AWG/kcmil min.	28
Conductor cross section AWG/kcmil max	16
Maximum operating voltage U _{max} AC	250 V AC
Maximum operating voltage U _{max} DC	125 V DC
Max. operating current I _{max}	1 A AC (inductive)
	1 A AC (ohmic)
	30 mA DC (inductive)
	0.2 A DC (ohmic)
Min. permissible switching capacity	0.12 VA (12 V, 10 mA)

Environmental conditions

Standards/regulations	IEC 61643-1
	EN 61643-11
	UL 1449
	IEEE C62.1
	IEEE C62.45
	IEEE C62.34

Certificates / Approvals

Certification

CB, CUL, GOST, KEMA, UL

Accessories

Item	Designation	Description
Bridges		
2880684	MPB SET VAL-CP-3S	Wiring bridge set, consisting of three flexible bridges 15 cm black, 1 bridge 27 cm blue.

Marking

0811228	X-PEN 0,35	Marker pen without ink cartridge, for manual labeling of markers, labeling extremely wipe-proof, line thickness 0.35 mm
0810038	ZBF 12:SO/CMS	Zack marker strip, flat, in 12 mm pitch, printed according to customer requirements, 5-section, divisible, color: white
0809735	ZBF 12:UNBEDRUCKT	Zack strip, flat, unprinted, 5-section, divisible, for labeling by the customer
0803595	ZBFM 5/WH:UNBEDRUCKT	Zack marker sheet, flat, unprinted: 120-section, 10 strips à 12 markers, sufficient for 120 terminal blocks, for all terminal blocks, pitch 5.2 mm, labeling with M-PEN or CMS system, color: white

Drawings

Dimensioned drawing

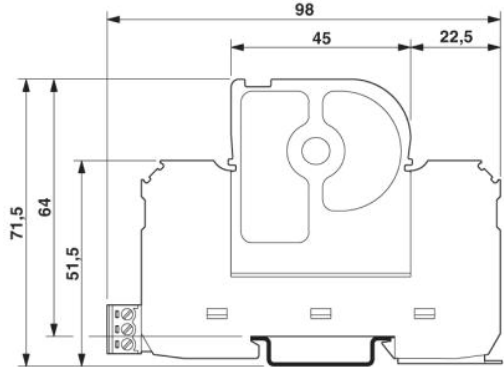

Circuit diagram

